

Verona

Wardrobe

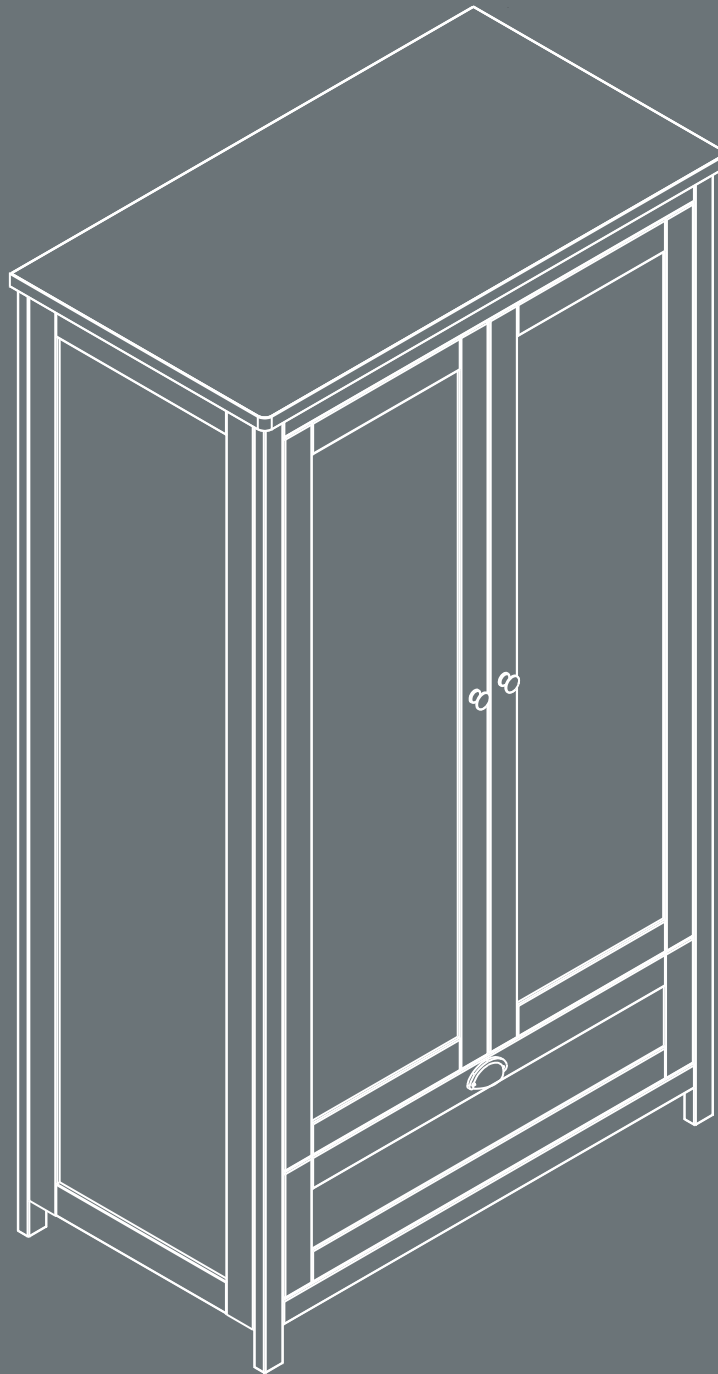

Assembly Instructions

Conforms to EN 14749:2016+A1:2021
Tutti Frutti Direct Ltd. 1068 High Road, London, N20 0QP
t: + 44 (0) 208 368 5800
e: support@tuttibambini.com
www.tuttibambini.com

Verona

Wardrobe

211342

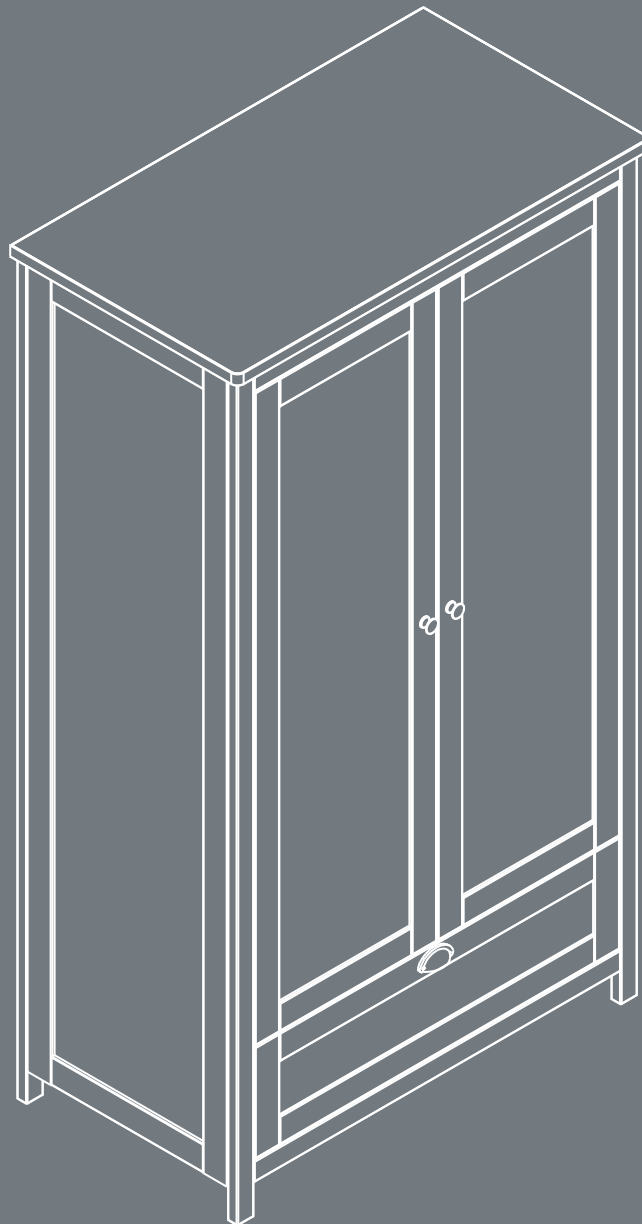

IMPORTANT: RETAIN FOR FUTURE REFERENCE,
READ CAREFULLY

Hello,

PLEASE READ THIS LEAFLET BEFORE ASSEMBLY

Dear Customer,

Thank you for buying Tutti Bambini furniture. Follow the instructions carefully and check that you have all the elements including the fittings before attempting assembly. If there are any missing or damaged parts, please inform us before you start the assembly. **WARNING:** installation shall be carried out exactly according to the manufacturer's instructions otherwise a safety risk can occur if incorrectly installed. Please note that incorrect assembly of your furniture will not be a basis for a claim against the product being damaged.

In the unlikely event that your furniture is found to be faulty, we ask that you send an email to: support@tuttibambini.com with the following information that can be found on the white label on the outside parcel.

- Name
- Postcode
- Contact telephone number
- Sales order number (found on white label)
 - Product name & colour
 - Damaged part number
- A photo or video of the damaged part





Tutti Bambini guarantee your product against faulty manufacture for a period of 12 months from date of receipt of purchase. This does not affect your statutory rights

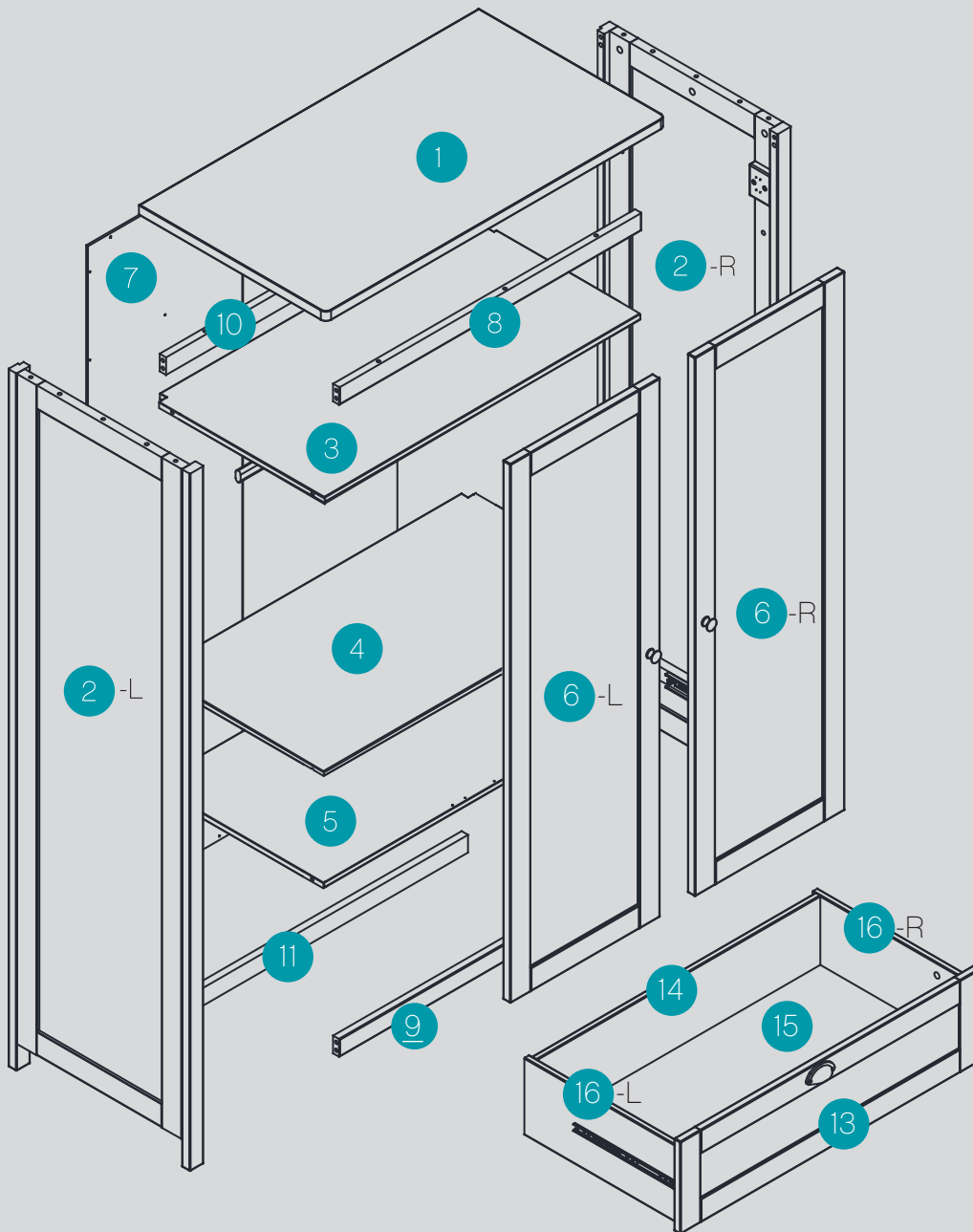

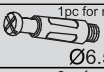
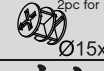

Team Tutti



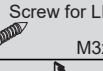

Parts List

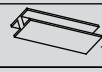
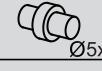

Hardware list

ID#	 1pc for replacement	Qty
A	Ø6.5x40mm	41 pc
ID#	 2pc for replacement	Qty
B	Ø15x11.5mm	42 pc
ID#		Qty
C		4 pc
ID#		Qty
D	Hanging rail ends	1 pc
ID#		Qty
E	Hanging rail support	1 pc
ID#		Qty
F	Bolts M6x24mm	1 pc

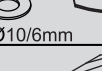
ID#		Qty
G	LED power supply box	1 pc
ID#		Qty
H	Screw for LED box M3x14mm	3 pc
ID#		Qty
I		6 pc
ID#	 1pc for replacement	Qty
J	Ø4x16mm	34 pc
ID#		Qty
K	LED hanging rail	1 pc
ID#		Qty
L		2 pc

ID#		Qty
M	1700mm	1 pc
ID#		Qty
N	Ø5x18mm	4 pc
ID#		Qty
O		1 pc
ID#		Qty
P	Ø10/6mm 200x30mm	1 pc
ID#		Qty
Q	M8*40mm	8 pc
ID#		Qty
R		1 pc



Assembling into wardrobe

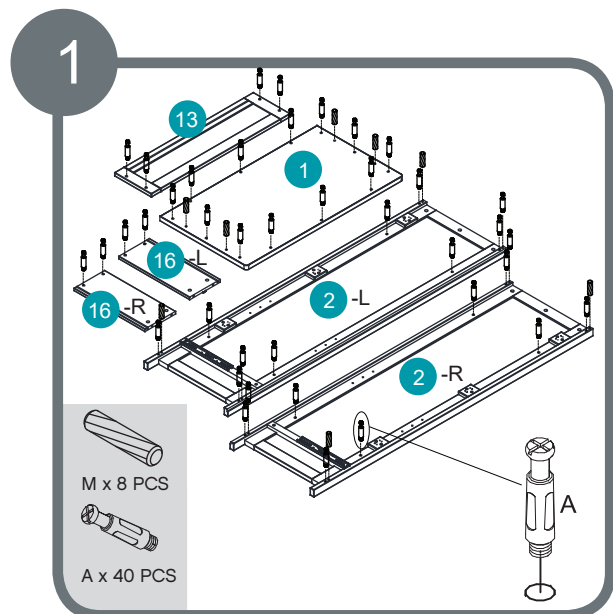
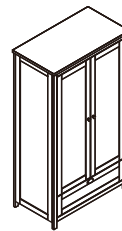

Assemble metal dowels A x 40.
Assemble wooden dowels M x 8.

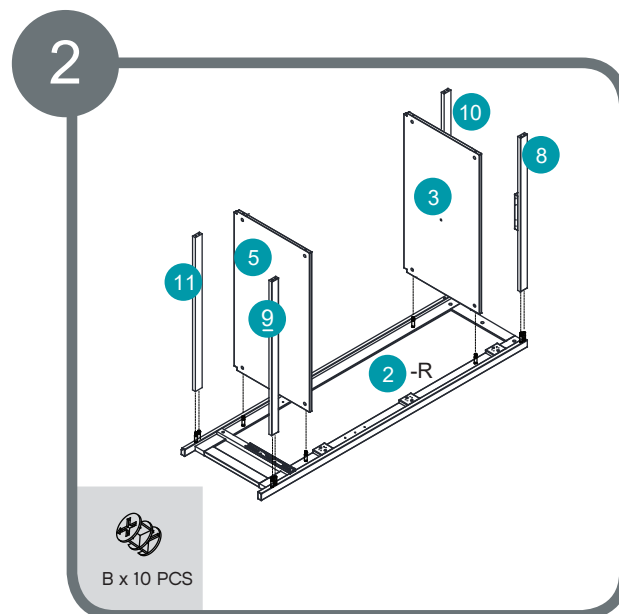

Assemble locking nuts 10 x B.

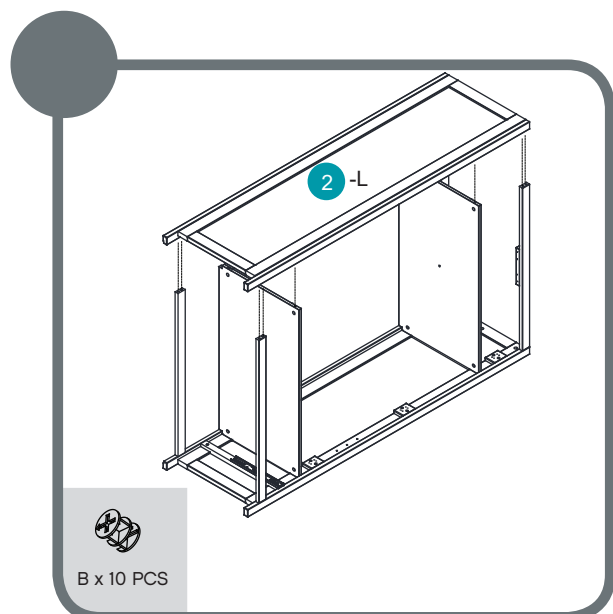

Assemble locking nuts 10 x B.

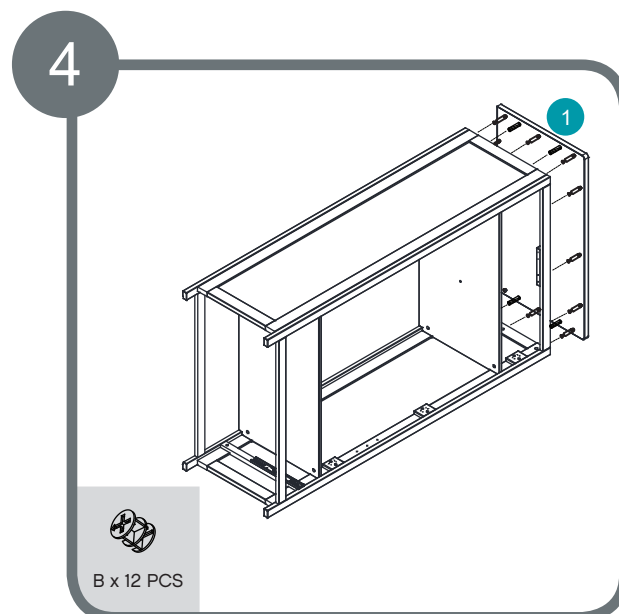

Assemble locking nuts 12 x B.

Assembling into wardrobe

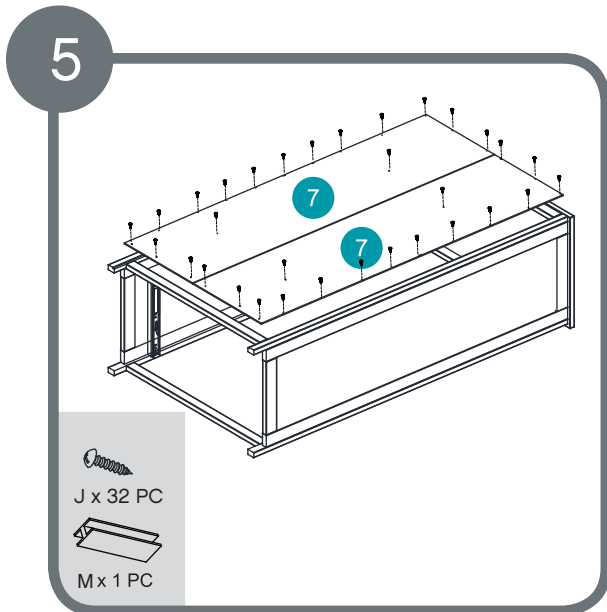
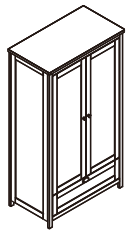

Assemble screw 32 x J.

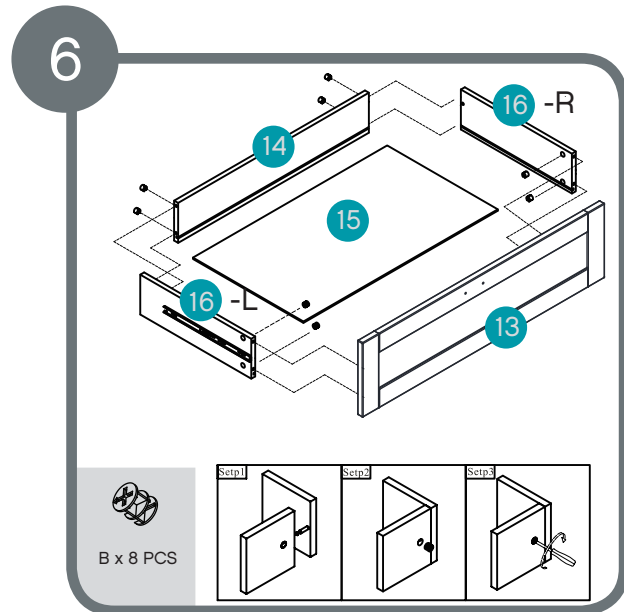

Assemble locking nuts 8 x B.

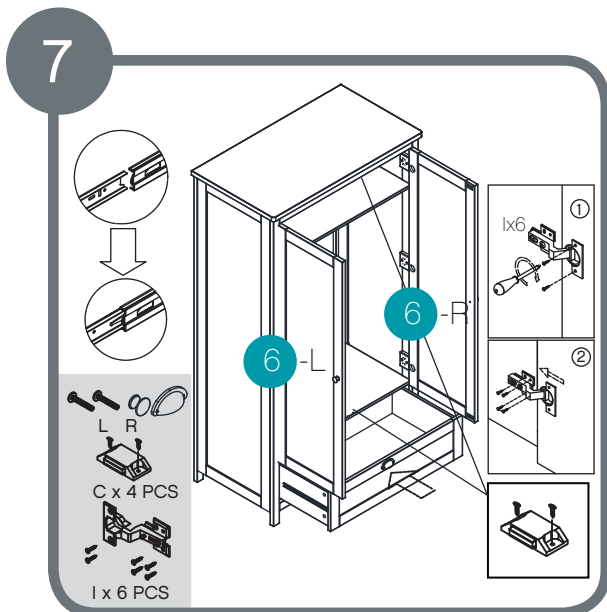

Attach door hinges I to the doors using screws.
Attach handle L R to door and drawers.
Assemble magnetic catches to parts 8 and parts 5

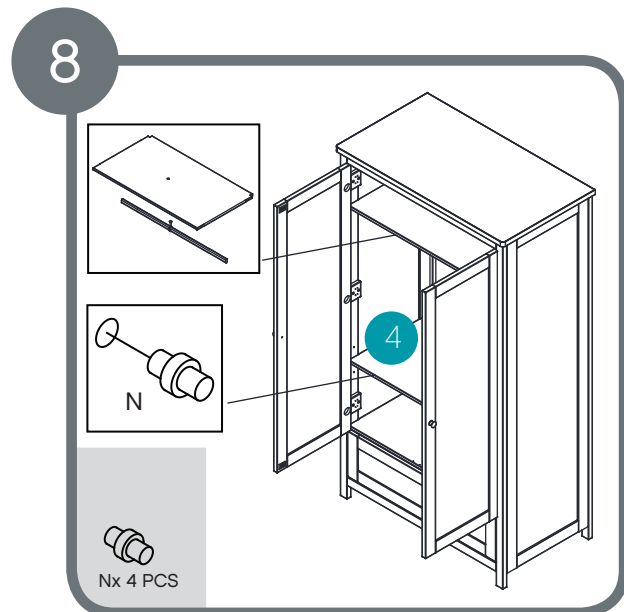

Attach shelf supports N to the side then put the shelf on the shelf support.



Assembling into wardrobe

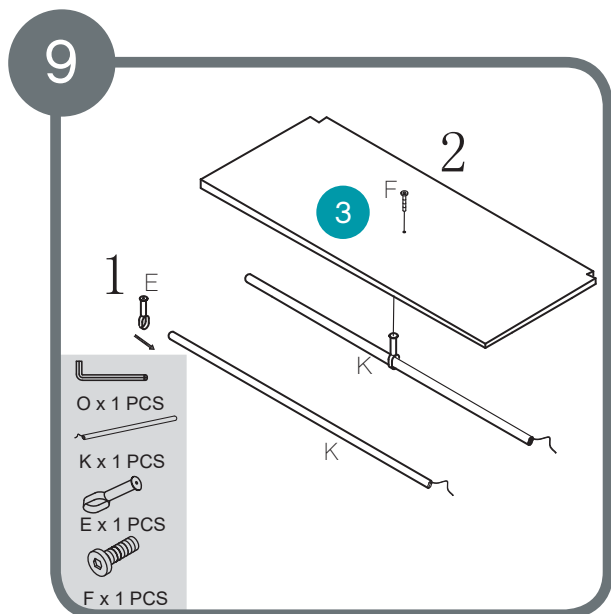
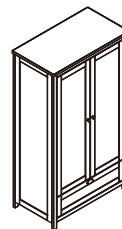

Attach hanging rail supports E to the led hanging rail K, then assemble to the shelf using 1 x F screws

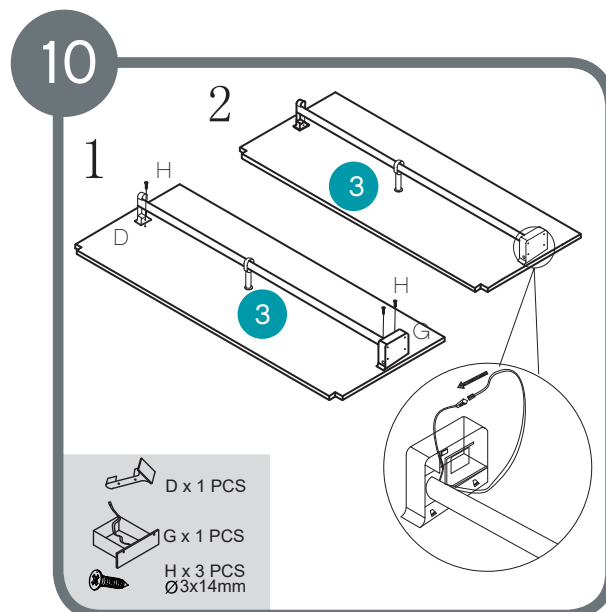

Assemble led hanging rail to the shelf using screws H, hanging rail ends D and led power supply box G

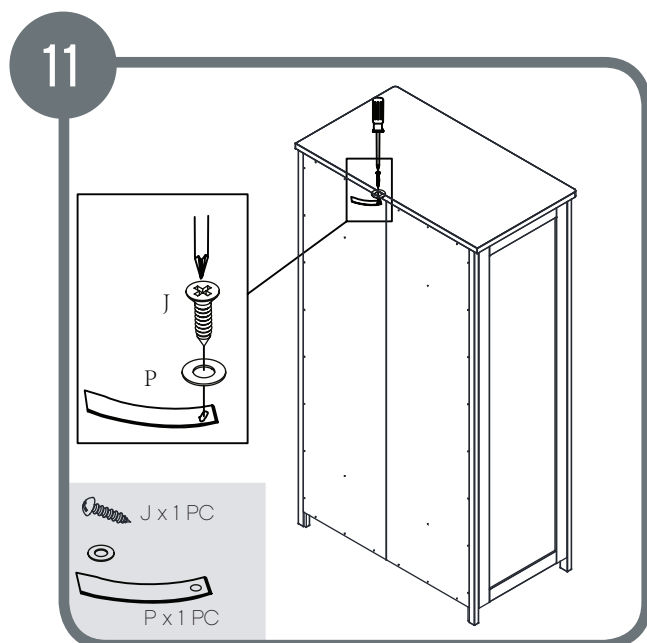

Fittings to attach the strap to the wall are not provided and suitable fittings for the wall type should be used.

Caution: The drawer is not provided with end stops that prevent it from being pulled out of the unit

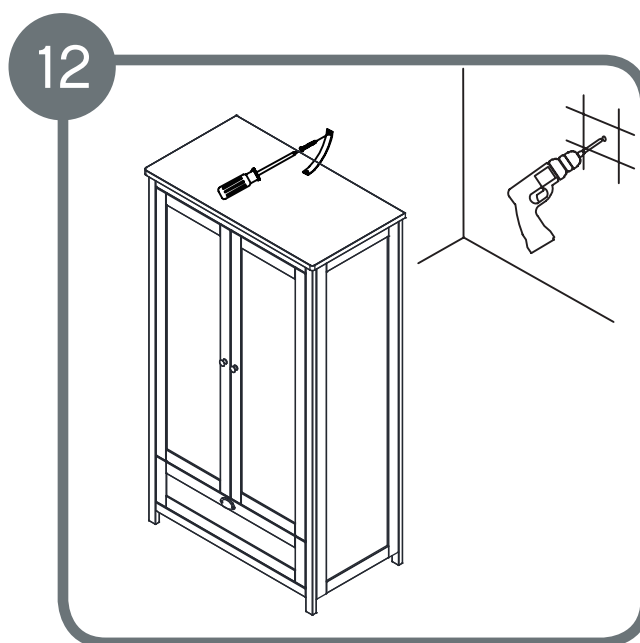

Safety advice and maintenance

IMPORTANT! KEEP FOR FUTURE REFERENCE: READ CAREFULLY

1. WARNING: Never leave your child unattended. The safety of your child is your responsibility.
2. WARNING: Do not allow children to climb on or in the wardrobe.
3. WARNING: Make sure the wardrobe is situated on a clear firm and level surface.
4. WARNING: Do not use the wardrobe if it is damaged or broken or there are parts missing. Use only spare parts approved by Tutti Bambini.
5. WARNING: Do not place the wardrobe near the vicinity of open fires or other surfaces of strong heat, such as gas or electric fires.
6. The wardrobe can be cleaned with a clean damp cloth. Do not use aggressive cleaning agents such as bleach or strong detergents.
7. Check on a regular basis that all fittings and screws are correctly tightened and are not damaged. Loose screws can pinch parts of the body and clothing resulting in the risk of strangulation.
8. Do not twist or pivot the wardrobe, if the wardrobe is to be moved always lift with at least two people.
9. WARNING: In order to prevent overturning this product must be used with proper wall attachment devices.
10. Any additional or replacement parts are obtained from the Tutti Bambini or its distributor.

Product development dictates that components may occasionally differ from the ones shown in the diagrams of these instructions. The right to change the specifications and design of the furniture without prior notice remains with the manufacturer.

Guarantee

All our products are produced from the finest quality materials and are manufactured under the strictest quality controls. We guarantee all our products or parts thereof against faulty manufacture for a period of one year from date of purchase. This guarantee is not effective against accidental damage or damage caused by incorrect use or neglect. This does not affect your statutory rights.

HINGE ADJUSTMENT INSTRUCTIONS

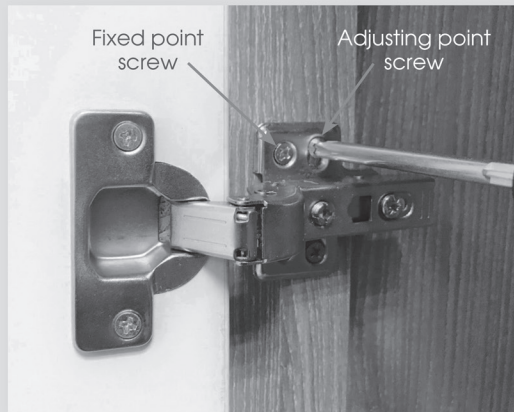
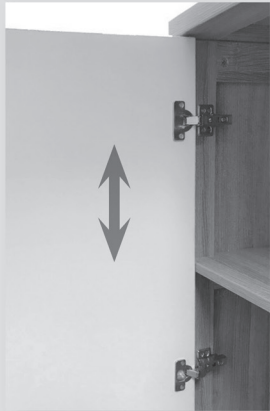

MOVING DOOR **UP OR DOWN**

Loosen top and bottom adjusting point screw on all hinges, push hinge up or down depending on door alignment then tighten screws and add fixed point screws.



MOVE DOOR **LEFT TO RIGHT**

Turn adjusting screw clockwise to move door to the right. Turn screw anticlockwise to move door to the left.



MOVING DOOR **IN OR OUT**

Loosen screw on all hinges, move door to desired point, then tighten all screws.

www.tuttibambini.com

Follow us    

TUTTI
bambini 

Join Us



Follow us on Facebook
TuttiBambiniUK



Follow us on Twitter
TuttiBambiniUK



Follow us on Instagram
TuttiBambiniUK

TUTTI
bambini 

www.tuttibambini.com